

Cerebellum Schematic Version 1.03b

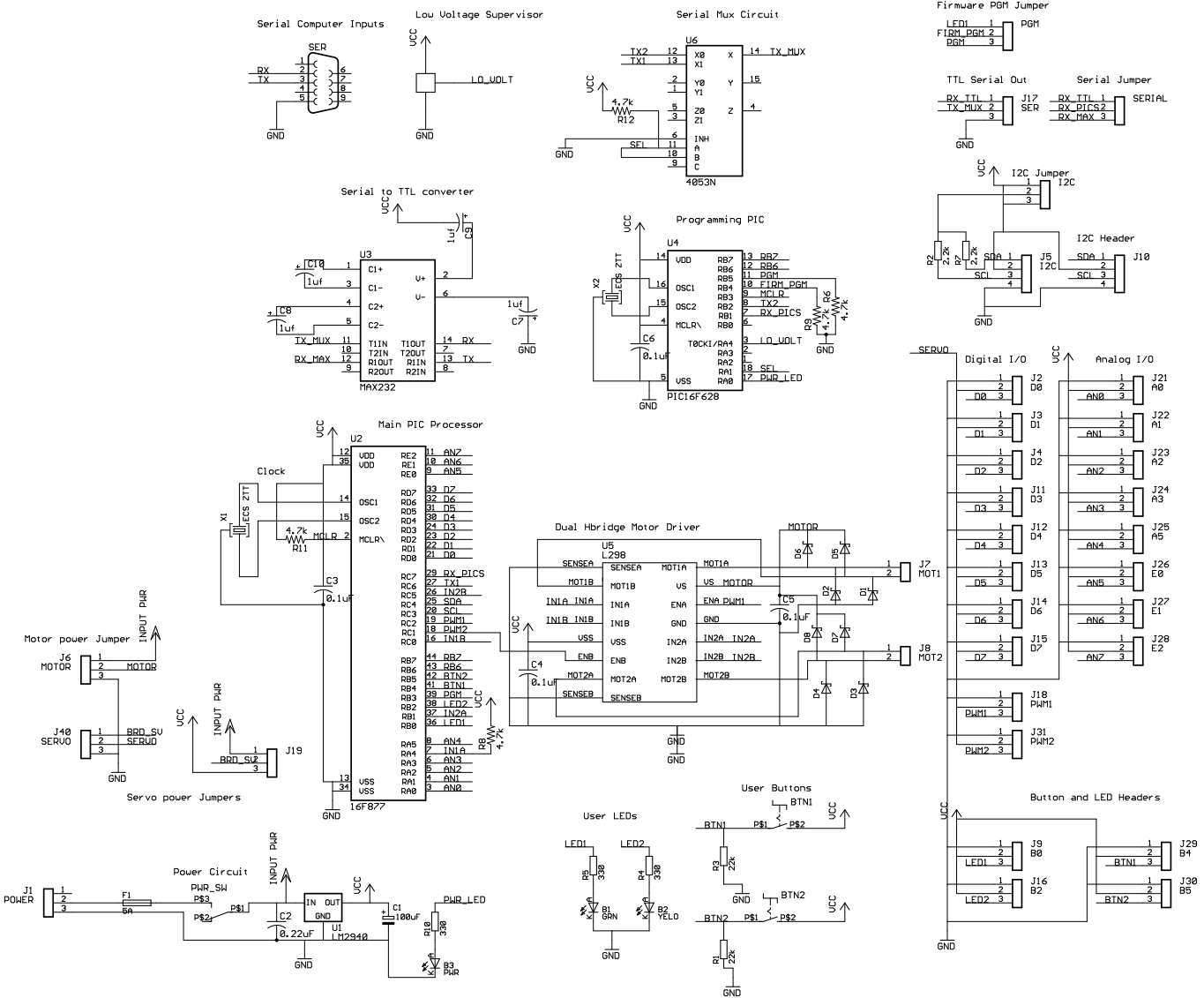

Copyright 2004 Botrics LLC